

The Flex-Panel® system from Wired Rite is a complete solution for custom vehicle wiring, and is installed as an overlay to the vehicle's pre-existing OEM wiring system. Flex-Panel facilitates the addition of electrical accessories including lights, electronics, and other equipment, and provides smart control of all accessories for safe and reliable operation.



**Eight Output 96 Amp [Max] Flex-Panel®
Programmable Power Module.**

The Flex-Panel Power Modules deliver power to vehicle accessories. Each Power Module has switched source outputs from 5 to 30 Amps controlled by the on-board microprocessor and the user-defined control program. Solid state technology enables smaller size and simpler wiring than with larger systems using relays. Each output is circuit-protected, shutting off immediately if too much current is detected.

Various Power Modules are available to match your application. The Mid-Current Power Module provides a total of eight outputs ranging from 5A up to 20A. Two 5A and two 8A outputs are ideal for powering electronics such as GPS, radios, and computers. Two 15A and two 20A outputs enable more drive for lights and other accessories.

Built-in circuit protection

The Power Modules incorporate advanced circuit protection, removing the need for bulky and complex circuit breakers and fuse blocks. When circuits exceed their rating, they are shut down automatically and a status indicator facilitates troubleshooting. When the problem is repaired, the circuit is reactivated automatically without changing fuses or resetting breakers.

Flexible and customizable

In addition to switching current for accessories, each Power Module has inputs and outputs to help you customize a system to meet your specific needs. Eight switch/sensor inputs accept signals from switches or sensors for accessory status information such as “Boom Out of Stow” or “Outrigger deployed”. Each module also has eight LED/Legend drivers for flexibility to drive status indicators or troubleshooting tools.

	Mid-Current Power Module
# Outputs @5A	2
# Outputs @8A	2
# Outputs @15A	2
# Outputs @20A	2
Max Current Total	96A
Universal Inputs	8
LED/Legend Drivers	8
Dimensions (inches)	4.25”x5”x1.2”
Module Current (typ.)	<10mA

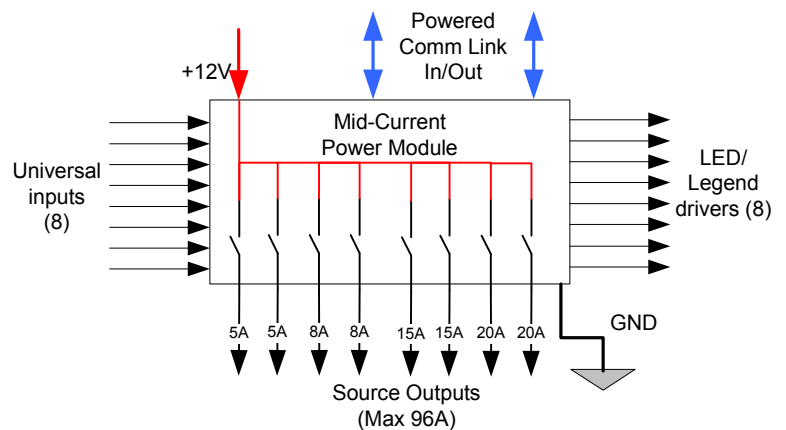

Specifications

Universal Inputs. Power Module inputs are Universal Inputs, and can be used as either analog or digital inputs. Analog signals provided to the Universal Inputs (0-15V) are converted by the processor for applications such as monitoring thresholds. Logic signals provided to the Universal Inputs can be 5V or 12V logic, and can be either “Hi True” or “Lo True”. The readings from all Universal Inputs are made available to the Flex-Panel Control Program. Inputs connections are made through the Interface Connector.

LED/Legend Output Drivers (+5V). LED driver outputs (5V) are typically used for switch panel backlit legends or other indicators and supplement those provided in the Switch Panel or Legend Module. Outputs are set based on the Control Program and connections are made through the Interface Connector.

Interface Connector. Universal Input and LED Driver Output connections are made through the Power Module Interface Connector. Mating connectors and pins are supplied with the system, and wire harnessing is available up to 40 feet in length. A standalone module (only one module in system) can be connected directly via the Input/Output Connector without the need for the Powered Comm Link, with the functions still controlled by the Control Program.

Host function. Power Modules can perform the role of host, serving as the primary controller of the system, for up to eight Flex-Panel modules. The host directs the communications traffic among modules and contains the system definitions and Control Program.

Voltage: 9-15V DC from vehicle battery. Power Module outputs turn off automatically when the supply voltage drops below 9V. The processor continues to run when the supply is >7V.

Operating temperature range: -25 to +50 degrees C.

Storage temperature range: -40 to +90 degrees C.

For more go to www.wiredrite.com